

HOW TO OBTAIN SERVICE

Eagle Electronics will provide quick and efficient service with genuine Eagle parts should you ever require it. If you do require service, call or write us at the address below before sending in the unit. We may be able to save you the inconvenience of sending the unit back for repairs. If you do have to return the unit for service, please enclose a letter stating the problem that you are having with the unit. This will assist us in the testing and repair of your depth sounder.

Mail to: EAGLE ELECTRONICS
P.O. BOX 669
CATOOSA, OKLAHOMA 74015

If you live out of the state of Oklahoma, call 1-800-331-2301.

If you live in the state of Oklahoma, call collect 918-266-5373.

SCHEMATIC DIAGRAM & PARTS LIST

Should you desire a schematic and parts list for your EAGLE depth sounder, send \$1.00 to the address above and it will be mailed to you promptly. Please be sure and give us the model and serial number of your EAGLE.



EAGLE

MODEL SILENT

SIX/SIXTY

INSTALLATION INSTRUCTIONS



EAGLE ELECTRONICS
P.O. BOX 669, CATOOSA, OKLA. 74015

INTRODUCTION

Thank you for selecting a waterproof EAGLE depth sounder. We believe that it is the finest unit available today, manufactured right here in the U.S.A. to precision tolerances.

To fully enjoy the advantages this equipment brings to you, we suggest that you read this manual thoroughly before any attempt at installation or use of this product.

Please fill out the warranty card and mail it to EAGLE ELECTRONICS. This will register your 1 year FULL warranty.

We suggest that you keep the original carton that the EAGLE was shipped in, so that if it ever needs to be returned to the factory for repairs, a suitable container will be available.

POWER CONNECTIONS

Power for the depth sounder is supplied by the boat's 12-volt DC electrical system. Power may be picked up at an accessory or power buss, but if you have problems with electrical interference, which is indicated by extraneous flashes on the dial, it can be minimized by connecting power directly to the battery. (See Figure 1.)

If a longer power cable is required, use ordinary #18 lamp cable available at any hardware or electrical supply store. Splices should be soldered. If this can't be done, use crimp-type splices. Simple twisting of splices may result in intermittent power connections which can cause interference. Tape all splices with electrical tape.

SPECIFICATIONS

Dimensions with knobs and gimbals	.7"H x 8"W x 6"D
Dial	0-60 (outer), 0-360 (inner)
Voltage	12 volts D.C. (operates 10-15 volts)
Current Drain	250 ma., one echo
Pulse Width	200-1000 μ s, adjustable
Output Power	200 watts peak to peak (typical) 25 watts RMS

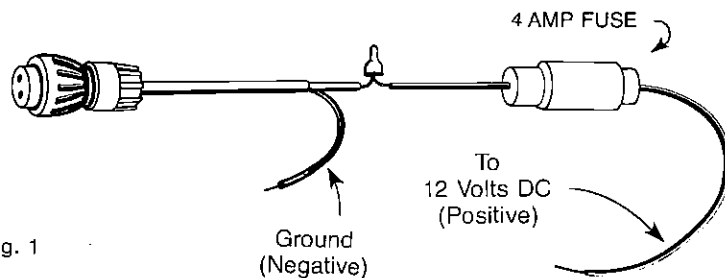

Fig. 1

FISH SIGNALS

Here are some things that will help you understand the signals that are displayed on your Eagle: A big fish returns a wide signal while a small fish returns a narrow one. A school of bait fish or minnows, nearly always near the surface, returns a great many thin, rapid signals. Wide signals beneath indicate the game fish which are often present under the school of little fellows to feed on them.

If you are cruising at three miles per hour while hunting fish with your Eagle, a single fish 30 feet deep will return a signal for approximately one second. (Three miles per hour is 4.4 feet per second and the diameter of the circle covered by the transducer is approximately four feet at that depth.) The signal returned by a fish 15 feet deep would last half a second, and from a fish 60 feet deep the signal would last approximately two seconds.

This is a good point to remember because fish often school in a horizontal plane, sometimes rather widely scattered in that exact level, but not all vertically, and a signal that lasts longer has to be made by more than one fish. Of course, fish suspended at different levels, even if only a

few inches higher or lower in the water, will return different signals at the corresponding depths on the dial.

Remember, many kinds of game fish like sharp drop-offs, rocky ledges, and underwater cliffs. But, as your boat moves across these spots, the Eagle will be unable to show the fish because the sloping bottom sends back such a wide signal.

Many kinds of fish remain suspended between the water surface and bottom during hot weather. Crappies will usually lie at a uniform depth similar to a horizontal blanket in the water.

A big school may extend 100 feet in each direction and as you pass over it you will get an almost constant signal, plus other flashing a few inches above and below. A school of white bass isn't likely to cover such a big area as a school of crappie sometimes does, especially in the summer and fall. The signals will show these fish occupying a greater spread vertically (8 to 10 feet). The larger game fish such as bass and walleye aren't likely to be so tightly grouped as white bass, crappie, or other panfish, and the individual members, being larger, return stronger signals.

TREES IN THE WATER

The signals on the dial shown here indicate an underwater tree with a few fish above it. The water is 50 feet deep, the tree 20 feet tall, and the fish are between ten and 13 feet deep. Limbs at various depths return individual signals and account for the wide band of signals on the dial. Brush appears similar, though not so tall.

Bass and panfish often hang around submerged vegetation, not only near the surface but down to depths of 25 or 30 feet, depending on the thermocline. To detect them, anchor bow and stern so your boat can't move. Constant signals indicate tree limbs. Signals that come and go or shift up and down are fish — limbs don't move.

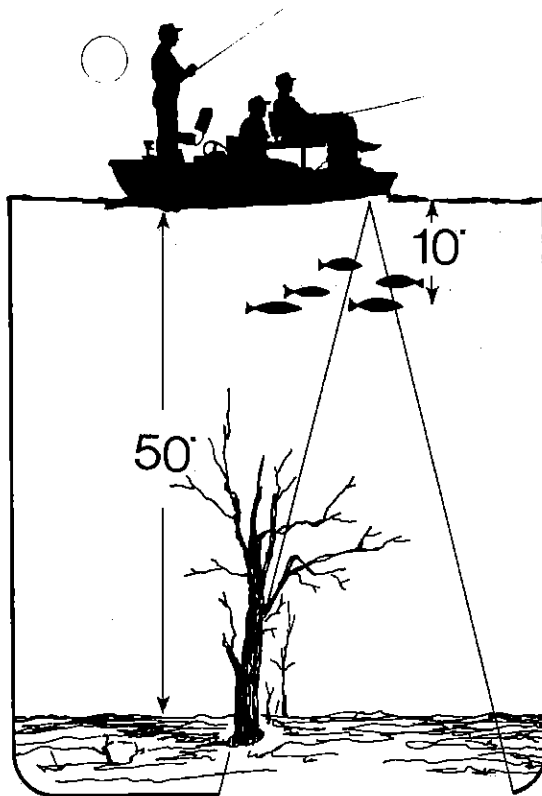
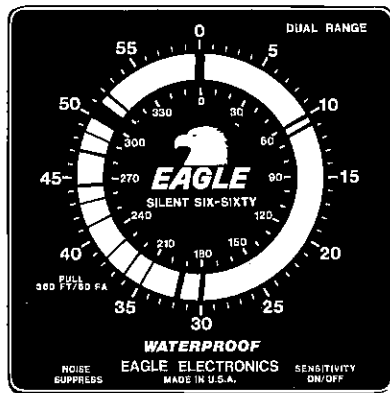

Fig. 21

IMPORTANT

When installing the power cable, make certain that the in-line fuse supplied with the unit is attached to the red conductor of the power cable as close to the power source as possible. This will protect both the unit and the power cable in case either is ever shorted. A connector is supplied to attach the fuse to the power cable.

The positive conductor in the power cable is the red conductor. The unit is protected from accidental polarity reversals and no damage will result if battery connections are wrong. However, the unit will not work.

MOUNTING

The depth sounder can be installed in any convenient location which has a flat surface. The adjustable yoke permits mounting on either a bottom or overhead supporting surface. If the unit is to be located in the vicinity of a compass, run it in position temporarily to make sure it does not affect compass readings. If compass heading changes, choose an alternate location. Note: the unit must be running when you make this test. Holes in the base of the bracket allow wood screw or bolt mounting.

Thread both knobs partially into the mounting bushings on the case. The gimbal bracket has slots in the top of it that allows the unit to "snap" in without removing the gimbal knobs. These slots will clear the threads of the gimbal knobs, but not the mounting bushing on the case.

The bracket sides will have to be spread slightly to clear the gimbal bushings, but will return to their original position when released. Holes in the gimbal bracket align with the gimbal bushings on the case and will not allow the unit to come off even in severe wave conditions. To remove the unit, simply loosen the gimbal knobs, spread the bracket sides away from the case, and pull the unit up and out of the bracket.

TRANSDUCER INSTALLATION

Two different mounting methods are available to install your EAGLE transducer, either transom mount or shoot-thru-hull. Although the transom mount will work on most hulls, we recommend that the shoot-thru-hull method be used only on solid fiberglass hulls. The transducer signals will penetrate single thicknesses of fiberglass, but will not go through porous materials such as wood or foam. The signals also will not pass through air pockets or voids in the fiberglass laminations. Regardless of which mounting method is used, the installation should be made in an area that has minimum water turbulence, air bubbles, and where the water is the smoothest.

The transducer cable should be routed away from other electrical wiring. Do not cut the transducer cable if it is too long. Instead, coil it and store the excess in an unobtrusive area. Transducer extension cables Model TEC-10 are available that will extend the cable 10 feet. If the

transducer cable needs to be extended longer than 10 feet, the depth sounder and transducer will need to be returned to the factory for re-alignment.

Fig. 2

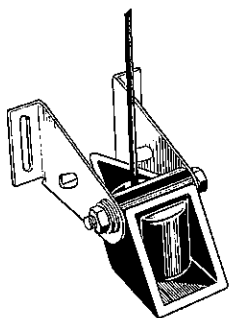

XD-2

Two other transducers are available for your EAGLE depth sounder. Model XD-2 is a high speed plastic unit that can be transom mounted or can shoot-thru-hull. It works well on deep vee hulls and aluminum boats. The other transducer (Model XD-3) is for trolling motor mounting or shoot-thru-hull.

Fig. 3



XD-3

A special bracket is available for the XD-2 transducer that will put it below the severe cavitation layer that is sometimes present on aluminum boats. The model number for this bracket is XMB-2.

Fig. 4

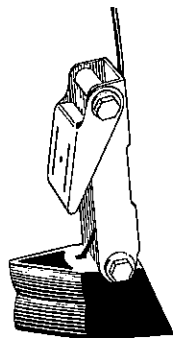

XMB-2

SHOOTING THROUGH THE HULL

1. Mounting inside the hull is recommended for fiberglass hulls in an area that does not have air bubbles in the resin or separated fiberglass layers. The sonar signal must pass through solid fiberglass. A successful transducer installation can be made on hulls that have flotation materials (such as wood or foam) in between layers of fiberglass if the material is removed from the chosen area. For example,

Fig. 5

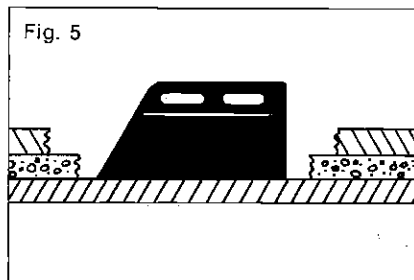

some manufacturers use a layer of fiberglass, then a core of balsa wood, and then the outer layer of fiberglass. By removing the inner layer of fiberglass and the balsa wood core, the outer layer of

SIGNALS RETURNED BY A ROCKY BOTTOM

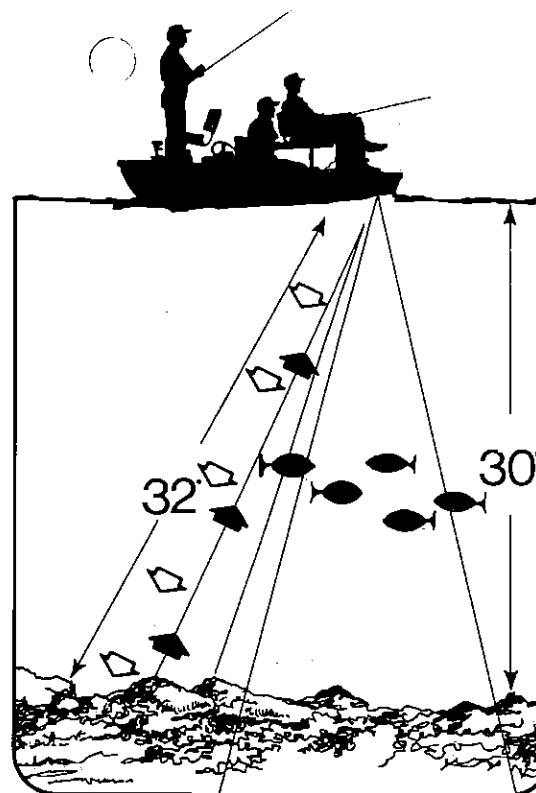
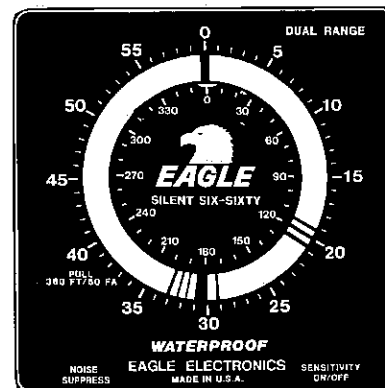
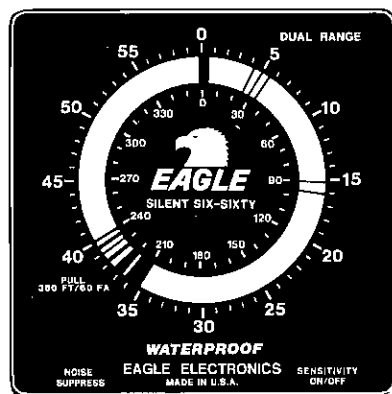

Fig. 20

The signals returned from a rocky bottom are quite confusing when you first see them. The EAGLE's dial will indicate the level of the bottom at the correct depth, but it will also show clear, thin signals above and below the wider main bottom signal. This is explained by the fact that the rocks near the outer edge of the cone of sound waves are farther from the transducer than those in the center, while the tops of the latter are closer than the bottom.

This drawing also shows the typical signals indicating a school of white bass or bluegills at a depth of twenty feet. The signals are brighter than those returned by bait fish.

WIDTH OF SIGNAL INDICATES SIZE OF FISH



Small minnows or bait fish appear on the dial as thin, pale lines. If they are tightly schooled they may cover a depth of from five to ten feet on the dial with a few pale lines for individual minnows at the bottom of the school. Your EAGLE will indicate even a single minnow 30 feet beneath the surface of the water.

Obviously, the back of a big fish offers a larger surface to reflect the signal than the back of a small fish. Consequently, you get a wider and brighter signal on the dial and, even though you can't tell the exact size of the fish from the signal, it does give you a good clue so that you can instantly tell big ones from little ones.

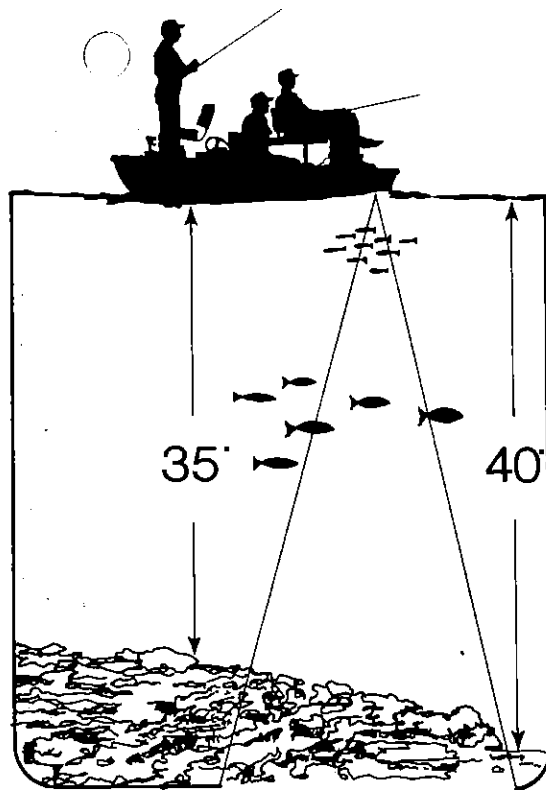

Fig. 19

fiberglass and gel coat are exposed. The transducer can then be epoxied directly to this outer layer. (See Figure 5.) When epoxy is poured into the hole and the transducer placed into the epoxy, the hull is still structurally rigid and no weak points are made.

2. The chosen area should be in the aft one-third of the hull on planing boats, and forward of the engines and/or water intakes in displacement hulls. Water should flow smoothly in this area and it should stay in the water at all speeds.

face of the transducer and the hull. Plug the transducer into the unit and turn the depth sounder on. Operate the boat at all speeds and move the transducer until the best location is found for maximum signal reception and minimum cavitation noise (cavitation is caused by water turbulence and shows up as narrow signals all around the sonar dial.)

4. If the chosen area is void of potential problems, sand the surface of the hull and the face of the transducer with

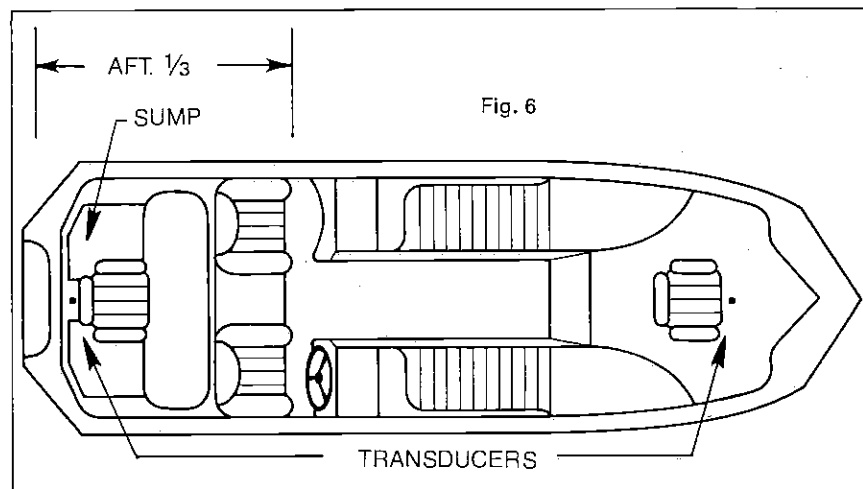

Fig. 6

3. Before permanently bonding the transducer to the hull, trial runs are recommended to find the best mounting location. Once an area has been determined to be a good spot for the transducer to be mounted, add some water to the area, and place the transducer in it face down. This will eliminate air between the

100 grit sandpaper. The surface must be flat enough so that the entire transducer face is in contact with the hull prior to bonding.

5. Build a small dam out of caulking compound or modeling clay around the chosen area of the transducer. (Do not use PLAY-DOH.) (See Figure 7.)

SIGNALS FROM STEEP, ROCKY LEDGES

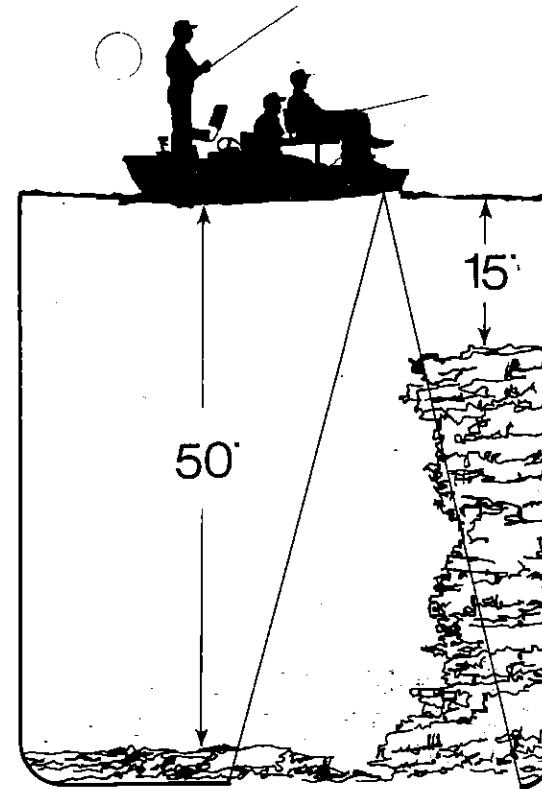
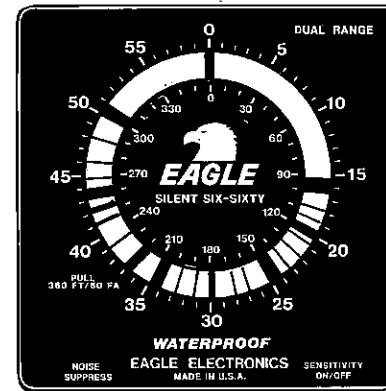
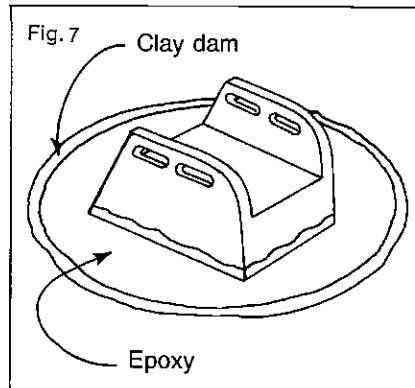

Fig. 18

Your EAGLE translates time into distance — the farther the sound waves go, the longer it takes them to return to the transducer and the greater the depth shown on the dial. Nowhere is this shown more clearly than when your boat passes over a steep, rocky underwater ledge or cliff, either vertical or inclined at a steep angle.

Assume the top of the cliff is 15 feet beneath the surface of the water, and the bottom is 50 feet deep. Sound waves will hit rough spots on the cliff all the way down. As the result, the signals on the dial will cover an area extending from 15 to 50 feet — a condition that could easily lead to confusion until you understand it.



- Use a good quality two-part epoxy to bond the transducer to the hull. Do not use silicone rubber sealer or any adhesive that does not get rock hard. Follow the instructions on the epoxy package and mix it thoroughly. Apply a small amount on the entire face of the transducer and pour 1/16" thick level into the area contained by the clay dam. Place the transducer into the epoxy by pushing and turning to force all of the air bubbles out from under the transducer face. The transducer face should be parallel with the boat hull, with a minimum amount of epoxy between hull and transducer. Weight the transducer down until the epoxy cures.
- Route the transducer cable along gunwales and away from power cables.

TRANSOM MOUNT

- Loosely attach the brackets to the transducer with the hardware provided.
- Locate the bracket where the flow of water is smoothest with minimum turbulence

and bubbles. Also, the bracket or transducer should not interfere with the boat trailer or hauling of the boat.

- Typically, the transducer should be located half-way between the center of the transom and the outside edge of the hull. (See Figure 8.)

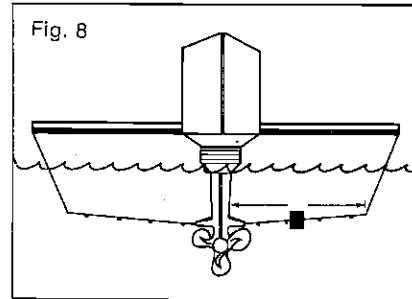

The transducer should be mounted away from stakes, ribs, or other hull fittings that can cause turbulence.

- If the hull deadrise exceeds 4 degrees, a shoot-thru-hull mount on the centerline of the hull or an optional transducer should be used. (See Figure 9.)

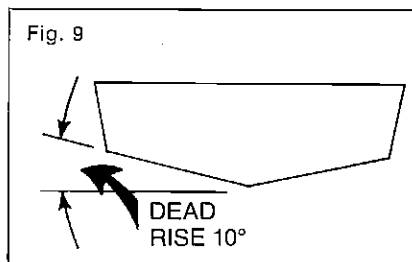

- Place the bracket against the transom in the selected area with the bottom of the transducer flush with the bottom of the hull. Align the transducer with the bottom of the boat hull by using a straight edge. Mark the transom for drilling

MUD BOTTOM CAUSES THE SIGNAL TO FADE

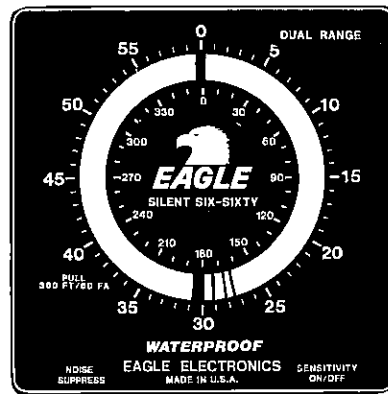

When you are hunting fish, with the gain adjusted properly to return a clear, bright signal from a bottom of gravel, sand, or shell, you will sometimes see the signal disappear. This doesn't mean that you have suddenly come to extremely deep water — the dial would have shown the drop-off with a wide band of signals in this case.

Instead, your boat is now above a mud bottom. Mud absorbs the sound waves. Turn up the gain. The bottom signal may be faint from a bottom of decaying vegetation under deep water. Fish will still show on the dial, however. Back over a hard bottom, you'll get multiple signals.

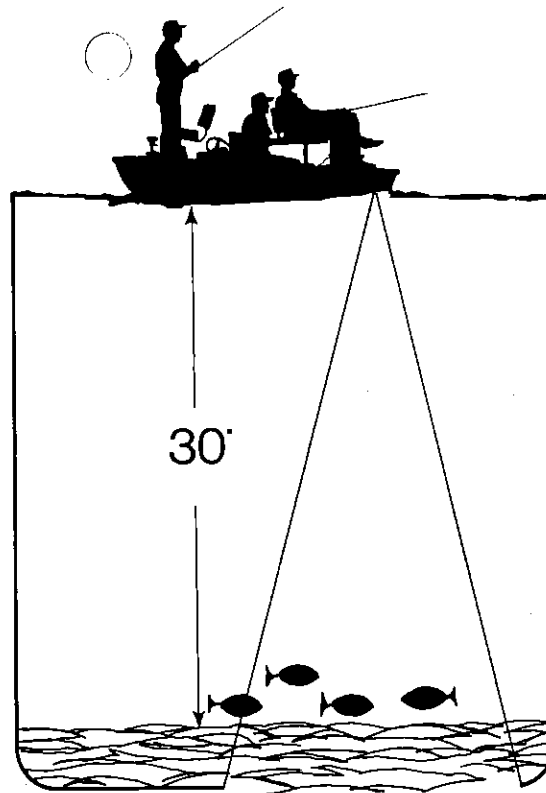

Mud and decayed vegetation

Fig. 17

the mounting holes at the top of the slots in the bracket.

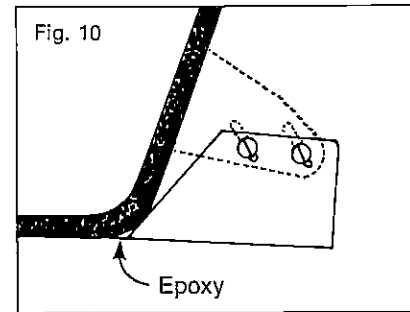

6. Mount the assembly to the transom with two #10 screws. Align the face of the transducer with the bottom of the hull with a straight edge. Tighten all screws.
7. Route the transducer cable to the depth sounder unit. Do not cut the transducer cable. If it is too long, coil and store the excess in an out-of-the-way location.
8. Make a test run to determine the results. Some boat hulls require lowering the back edge of the transducer 2° to 6°. If the run was satisfactory, drill two more holes in the bottom of the slots and install two more #10 screws. Note: The transducer must be against the transom for good results. After locking in place, fill any voids between the transom and the transducer with caulking compound, epoxy, or silicone adhesive.

OPERATION

SENSITIVITY AND "ON-OFF" KNOB

This knob operates in a manner similar to the volume control on

a radio. Turning the knob clockwise will turn the unit on, and turning the knob back the full counterclockwise position will turn the unit off. Turning the knob in a continued clockwise manner will increase the receiver sensitivity and weaker echos from deeper water can and will be observed on the dial. After mounting the transducer, turn the unit on by turning the sensitivity knob clockwise. You will see the constant surface signal at zero. Before long, you will see another signal — at ten feet if the water is ten feet deep. This signal indicates the bottom. It, too, should always show.

Continue turning the Sensitivity control toward the right and you will see a second bottom signal at double the depth of the first, or 20 feet. The sound waves have hit bottom, bounced back, hit the surface of the water, then bounced down and up again. Over a firm bottom you can increase the sensitivity until the dial shows three or four bottom signals at multiples of true depth.

The sensitivity is adjustable and you should always set it to return a steady bottom signal — nearly as bright as the zero signal — regardless of depth. Turn the knob counterclockwise when you begin to get the double bottom signal; clockwise when the bottom signal begins to fade. To show fish the sensitivity control should be set to show a strong, bright bottom signal. Many fishermen prefer to run the sensitivity control very high with the second bottom signal show-

ing to insure that they see all the underwater detail as well as fish.

NOISE SUPPRESS CONTROL

The noise suppress control knob can be used to cut down or eliminate false flashes on the dial. These false flashes can be caused by ignition interference from the boat's motor or by air bubbles passing over the face of the transducer.

Turning the knob clockwise increases the amount of noise suppress. Always use as little noise suppress as possible, because an increase in it cuts down on the ability of the unit to show separate signals or objects (such as fish) close together.

Increasing noise suppress does

control in the 60' position, the range should be read on the outside 0-60 scale. With the control in the 60 fathom position, the range may be read in fathoms on the outside 0-60 scale, or may be read in feet on the inside 0-360' scale on the faceplate.

HOW TO USE YOUR EAGLE DEPTH SOUNDER

The word "Sonar" is an abbreviation of Sound, Navigation, and Ranging. It was developed during World War II as a means of tracking enemy submarines. Sound travels at approximately 4,800 feet per second through water as compared to approximately 1,100 feet per second through air.

HARD CLAY, SAND, GRAVEL, SHELL BOTTOMS

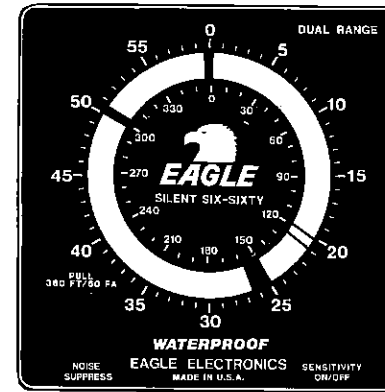

Some fish, including bass, catfish, walleyes, and crappies, occasionally lie right on the bottom. Even here the EAGLE will show them as you pass over, provided the bottom is smooth sand, shell, or gravel. Figure 16 shows a hard bottom with the sensitivity control adjusted so that a strong bottom signal is displayed with two fish at 20 and 21 feet. A second echo may be displayed that is twice as deep as the actual bottom signal when the sensitivity control is turned up high enough to see fish.

This is caused by the sound waves reflecting from the bottom, bounce back from the water's surface, return to the bottom and reflect back to the sonar unit. Many fishermen prefer to run the sensitivity control very high with the second bottom signal showing to insure that they see all the underwater details as well as fish.

The second echo is shown at 50 feet in figure 16.

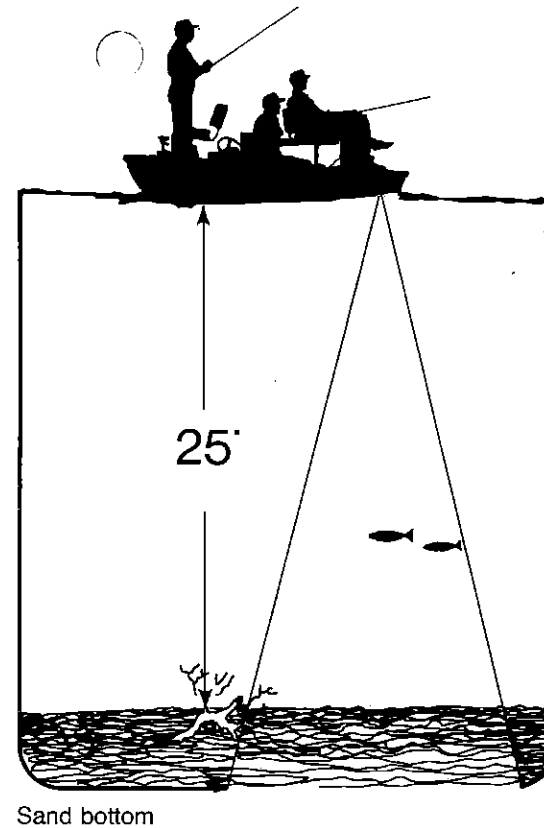

Fig. 16

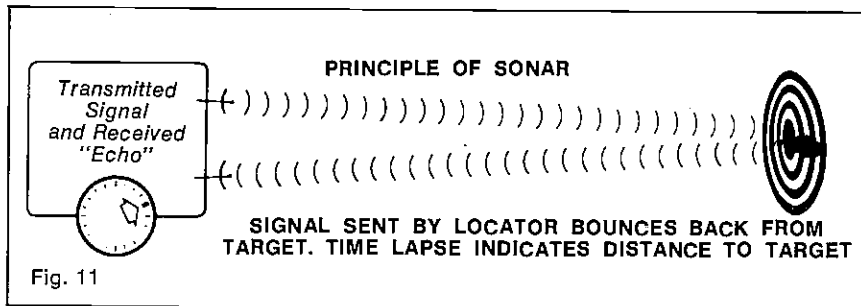

Fig. 11

not affect the *sensitivity* of the unit.

RANGE

The range control is used to select either the 0-60' or the 0-60 fathom (360') scale. The Noise Suppress control knob is used to change the scales. By pulling the knob out, the 0-60 fathom range is selected, and pushing the knob in switches the scale to the 60' range. With the

The way a sonar works in its simplest form is an electrical pulse is converted into a sound wave by the transducer and transmitted into the water. When this wave strikes an object, it rebounds. Since the speed of sound through water is known, the time lapse between the transmitted signal and the received echo can be measured and the distance to the object determined.

WEAK SIGNAL INDICATES GAIN TOO LOW

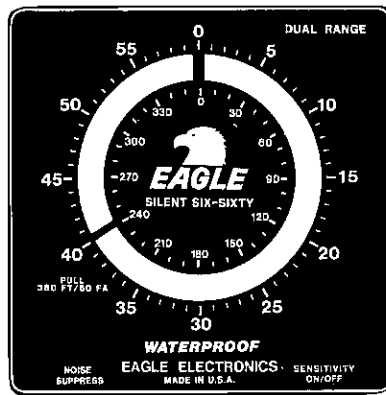

The sensitivity control on your EAGLE might be compared to the volume on a radio. Turn the sensitivity knob to the right and you increase the receiver sensitivity; turn it to the left and you reduce it. This feature is provided so that you can use your EAGLE over both deep and shallow water and you should always adjust the gain so that a bright bottom signal shows on the dial, regardless of depth. If you fail to do so and have only a faint bottom signal the dial will fail to show fish in the water between the transducer and the bottom. This condition is shown in the drawing above — the fish are there but they aren't shown on the dial because the gain is set too low.

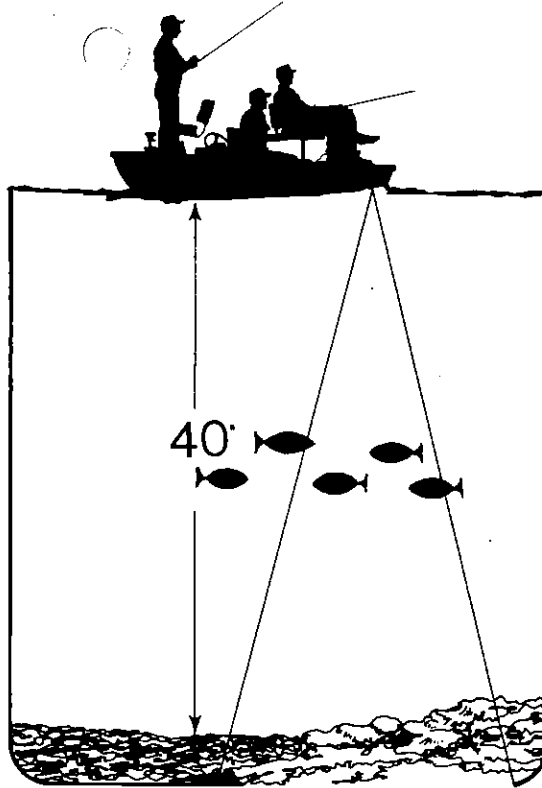
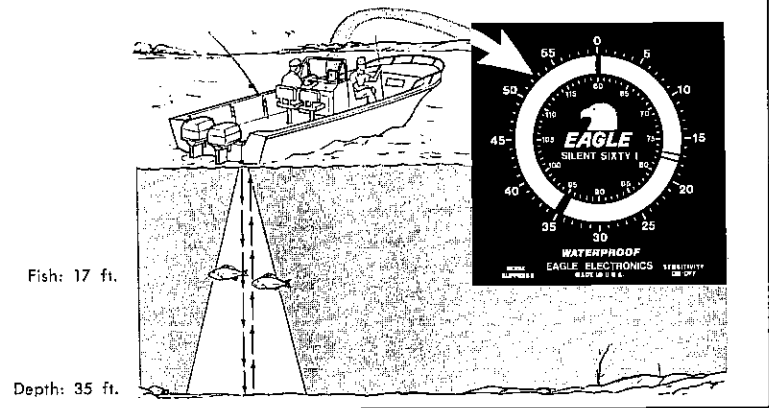

Fig. 15

Fig. 12



The Eagle depth sounder transmits a high frequency sound wave (which is inaudible to fish as well as humans) through the water. At the same time, a high intensity neon bulb whirls at a constant speed behind the dial on a disc driven by an accurately governed motor. The bulb is lighted every time the transmitter fires. This provides a visual reference point on the dial which is used as a starting point to measure depth, and as an indicator that the depth sounder is on. Even though the neon bulb flashes, it happens so often that the human eye sees it as a nearly constant light.

The bulb also flashes at the point on the dial that indicates the depth. The point is indicated by the length of time it takes the sound waves to reach the bottom and return. In addition, echoes returned from any object in the water between the surface and bottom fire the bulb, too. Since these echoes are also timed, they show the exact depth of any fish — or any number of fish — in the water. And because the sound waves from the transducer

go down into the water in a narrow cone angle, they tell, within a matter of a few feet, the fish's location as well as the depth. At a depth of 10 feet, the cone covers a circle that is approximately one foot in diameter; at 15 feet it is two feet wide, at 20 feet, three feet wide, the cone diameter is four feet wide. Regardless of depth, the cone of sound ends at the bottom. But an echo is also returned from any object between the transducer and the bottom.

Fig. 13

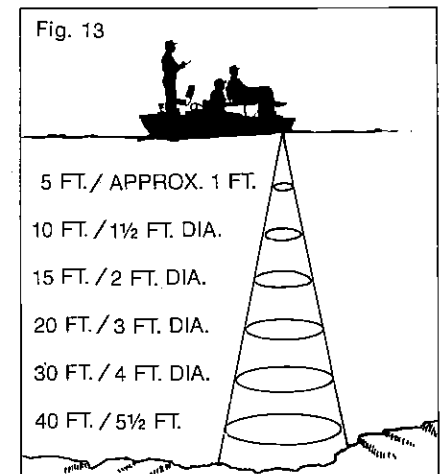

5 FT. / APPROX. 1 FT.

10 FT. / 1½ FT. DIA.

15 FT. / 2 FT. DIA.

20 FT. / 3 FT. DIA.

30 FT. / 4 FT. DIA.

40 FT. / 5½ FT.

As you move away from shore on a deep lake, the bottom signal will gradually move around the dial until it reaches zero. If the dial is calibrated to a depth of 60 feet, the water is 60 feet deep. Continue further, and the bottom signal will start around again. Add whatever figure it shows to 60 to get the correct depth. The inside dial on the Eagle Model Silent Sixty I is calibrated from 60 to 120 feet to help you read depths greater than 60 feet. Other Eagle models have dual ranges that allow you to change to a deeper scale when you go deeper than 60 feet.

SIGNAL INTERPRETATION

Because your Eagle is both extremely sensitive and powerful, it can give you an accurate picture of the kind of bottom over which your boat is passing. A bottom of firm sand, gravel, shell, or hard clay returns a bright, fairly wide signal. If you are traveling over such a bottom and the signal weakens, it means that you have moved over a soft mud bottom. A soft bottom absorbs the sound waves and returns a weak signal. In this case, simply turn up the sensitivity to get a good bottom reading.

A level bottom with scattered rocks returns the usual bottom signal — plus secondary signals both above and below it. This is caused by the different distances the sound waves travel. Those that go straight down, hit a rock, and come back indicate, correctly, that the top of the rock is above the level of the bottom. But the sound waves that hit a

rock toward the outer edge of the cone of sound waves and are reflected back to the transducer travel further. Consequently, their signals appear below the bottom signal.

A smooth bottom of solid rock returns a wide, bright signal. Broken rock of various sizes sends back an even wider one, with occasional flashes above and below the level of the true bottom, though these signals aren't so distinct as the ones returned by scattered rocks on a smooth bottom.

Big rocks or stumps on a smooth bottom send back signals above the level of a smooth bottom, the distance depending on their height. If you watch as you approach a post or a tree, however, you will often see the signal climb up, then descend the other side as you continue.

A steep slope returns a wide signal, the steeper the wider, with the signal returned from a high underwater cliff being the widest. The sure proof of a drop-off is the sudden change of the regular depth signal to a wide one, then back to the usual width, but either more shallow or deeper as the boat moves past.

Brush will return flashes of varying heights above the bottom signal. Weeds also tie in with the bottom, although they return weaker signals than brush or tree limbs. In most lakes, weeds don't grow in water more than 12 or 15 feet deep because of the lack of sunlight. Weeds make a great many thin, pale signals on the dial.

DETECTING A SMOOTH BOTTOM

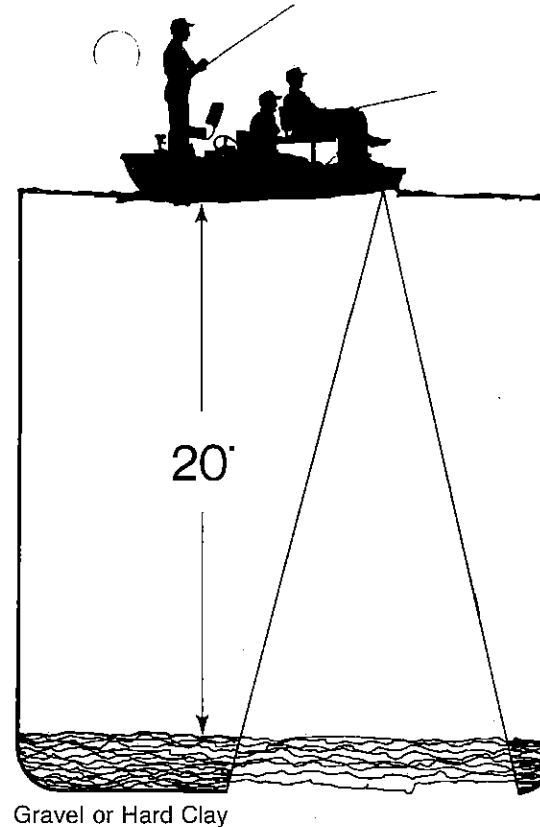

Fig. 14

The nicest bottoms to survey with your EAGLE are those that return a clear, bright signal, with no spikes either above or below it from scattered rocks. This is the easiest bottom signal of all to read and fish at any depth above it show up plainly on the dial. Nothing is more gratifying than to find a big school of largemouth bass over clean gravel or wall-eyes over a smooth sandbar — places that these two popular fish like and that are easy to fish by the bottom-bumping technique.

It is easy to get multiple signals on the dial from bottoms of this type. If you are over water 20 feet deep, for example, and turn up the gain you'll get signals at 20 and 40 feet.